

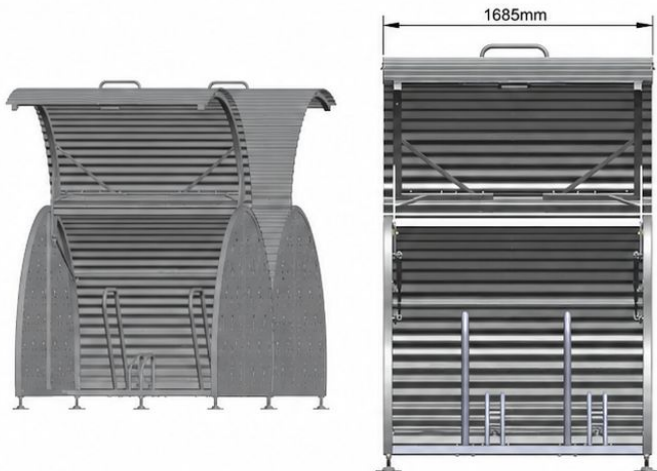

**GREASEMONKEY  
INFRASTRUCTURE**



# VeloBox Mini Specification



**PEDAL  
CYCLE  
DIAMOND**

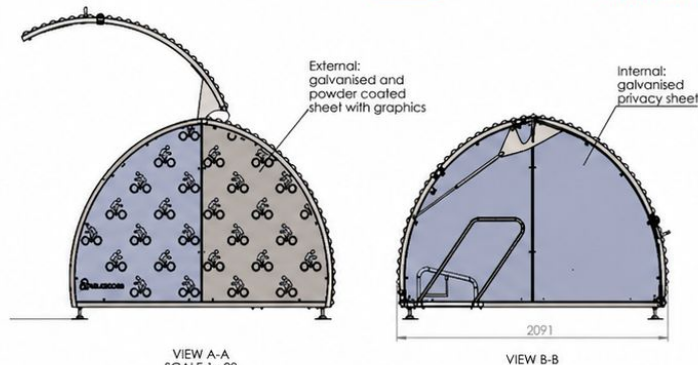

**Secured by Design**



**Official Police Security Initiative**

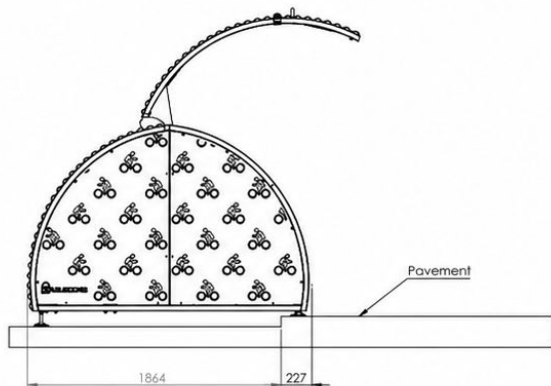

## VELOBOXES

- 2 units fit in one 2.4 x 4.8m parking space
- Height (closed): 1446mm
- Depth (closed): 2091mm
- Width: 1685mm
- **Hot dip galvanised** frame (BS EN ISO 1461)
- Gable ends and cladding available in **any RAL colour** (Standard colour: Anthracite)
- **Upward opening door** that remains largely within the footprint of the unit to minimise the risk of collision and other hazards to pedestrians
- Gas strut supported door: **easy to open and close**
- **Pulley handle** for short adults, children and people with a disability
- Galvanised, 150mm **adjustable feet**, suitable for resin anchors with 1-4 bolt fittings in each foot
- Wheelholders and supports for **4 bikes**
- Removable wheelholder to fit **pushchair, pram or scooter**
- Removable bike rack to fit **Cargo bikes** (lockable to frame)
- **High visibility reflectors** at either end and at the back of the Velobox
- Optional -integrated- **accessories**:  
Planter, bench, electric bike charger, EV charger, privacy sheets
- **10 year guarantee** if maintained by, or in accordance with Greasemonkey Velobox care plan

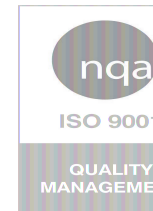

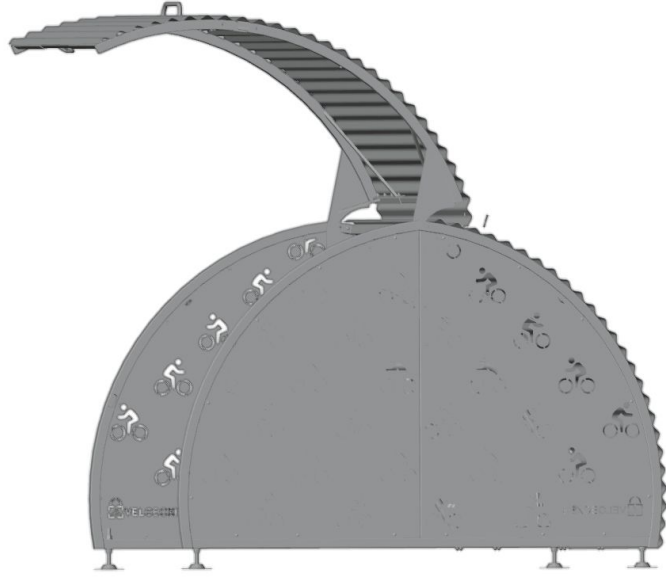
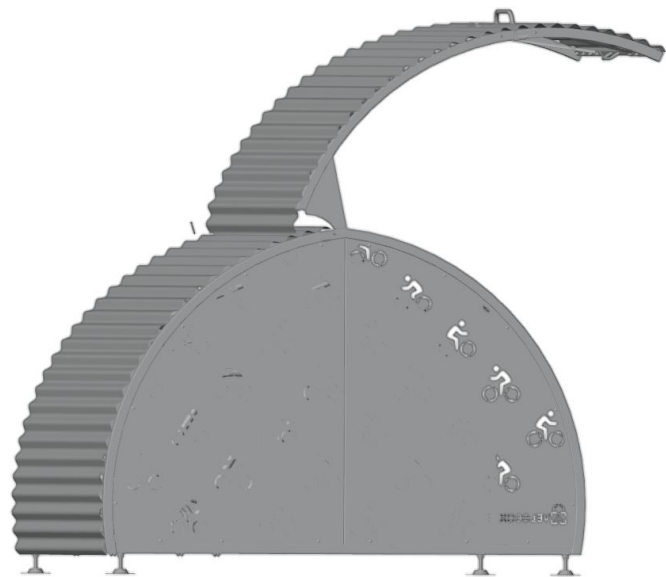

**PEDAL  
CYCLE  
DIAMOND**

**Secured by Design**



**Official Police Security Initiative**



ISO 14000

ENVIRONMENTAL  
MANAGEMENT



ISO 9000

QUALITY  
MANAGEMENT

## VELOBOXES - Security

1. Designed and tested to **Sold Secure Pedal Cycle Diamond** (5 minute resistance hand and power tools)
2. **Seven-pin**, radial pin tumbler **locking cylinder** with stainless steel and brass body, **anti-drill centre and pick resistance**
3. **Master key options** available with custom keys that require prior authorization before new keys can be cut
4. 15mm **drill and grinder resistant**, stainless steel face plate
5. 70 stainless steel **oversized rivets** securing cladding
6. 20 stainless steel **drill resistant coach bolts** and 18 internal stainless steel oversized rivets securing gable ends
7. M8 Stainless steel **resistor security bolts** securing all internal assembly components
8. Stainless steel **grinder resistant locking rods**
9. **Compact gear actuator** to resist bending
10. Locking rod **entry insert** to prevent drilling and hammering of rods from outside the unit
11. Internal **lock cover** to prevent users tampering with locking mechanism
12. Door **guide plate** to prevent leverage attacks at edges of door
13. Box section steel frame provides a **stiff body** preventing bending and misalignment
14. Unit operating temperature **-30°C to +80°**



2,3

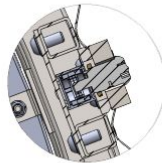

4,9,11



5



6



7,13



10



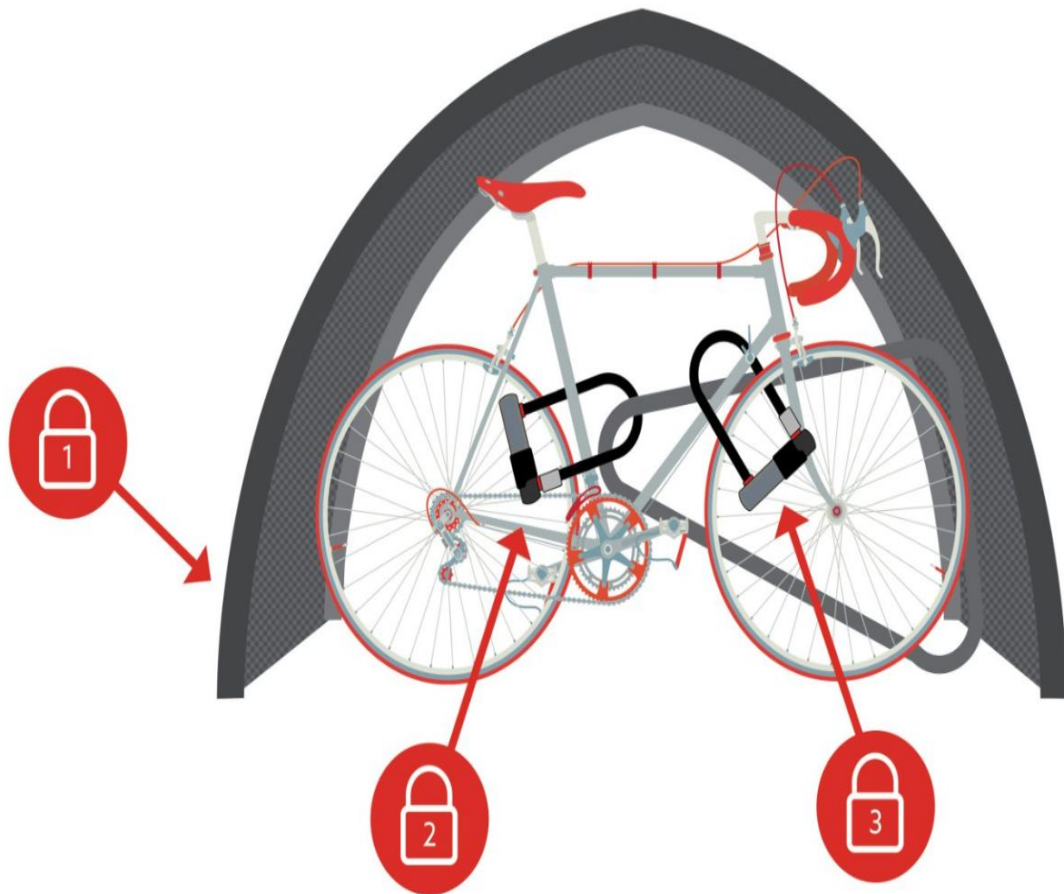

## Veloboxes 3 Point Locking System

1. The Velobox is locked at the point of entry
2. Lock your frame and wheel to the Velobox stand using a U-Lock
3. Secure your front wheel to the stand using either a U-Lock or Cable lock

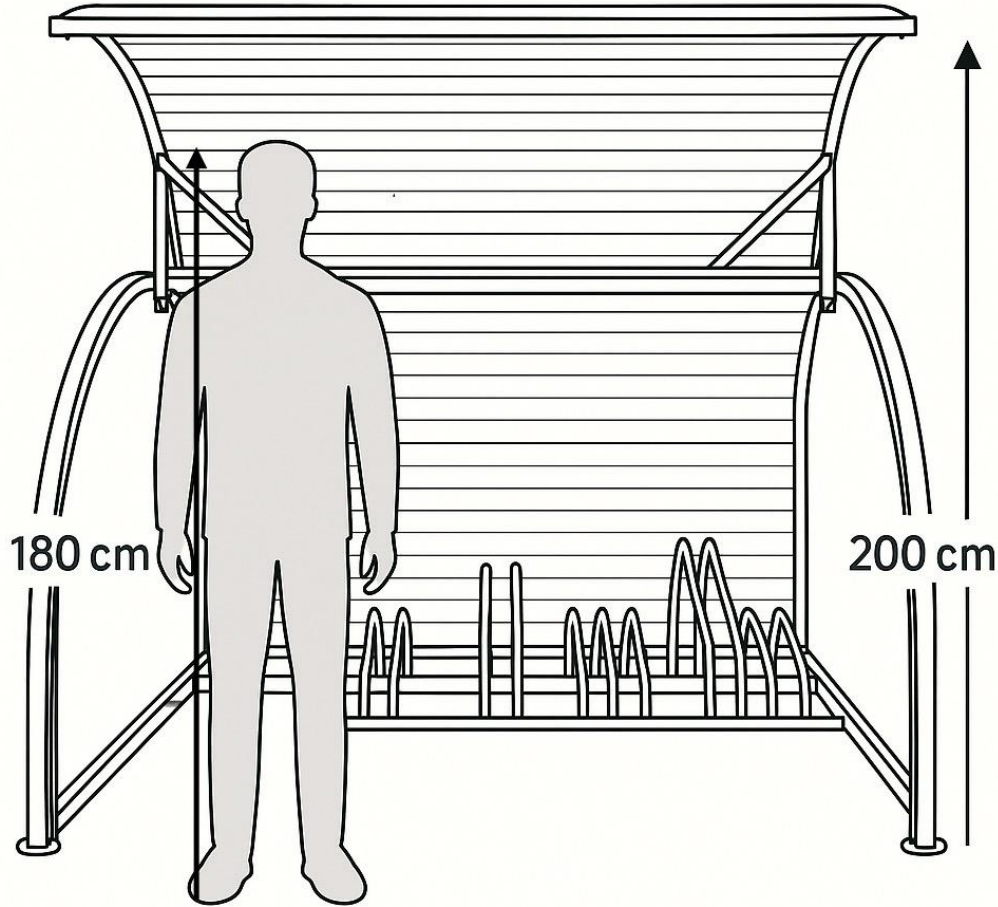

## Why Door Height Matters: A Clear Advantage Over Competitors

The generous door-opening height of our VeloBox measuring a full **200 cm**, provides noticeably improved accessibility and day-to-day usability. Unlike competitor units that open to only **175 cm**, our taller opening ensures that the majority of users can walk in and out comfortably without needing to duck or adjust their posture. This reduces the risk of knocks or strains, particularly when manoeuvring bikes, helmets, or bags. The increased clearance also enhances visibility inside the unit, making it easier to load and unload bicycles quickly and safely. Overall, the higher door-opening height contributes to a more user-friendly, inclusive, and premium storage experience.

# Allowable bike dimensions

Grease Monkey:  
(L) 2000mm x (H) 1300mm

Cyclehoop (Orange): ●  
(L) 1800mm x (H) 1200mm

Lockit Safe (Blue): ●  
(L) 1900mm x (H) 1100mm

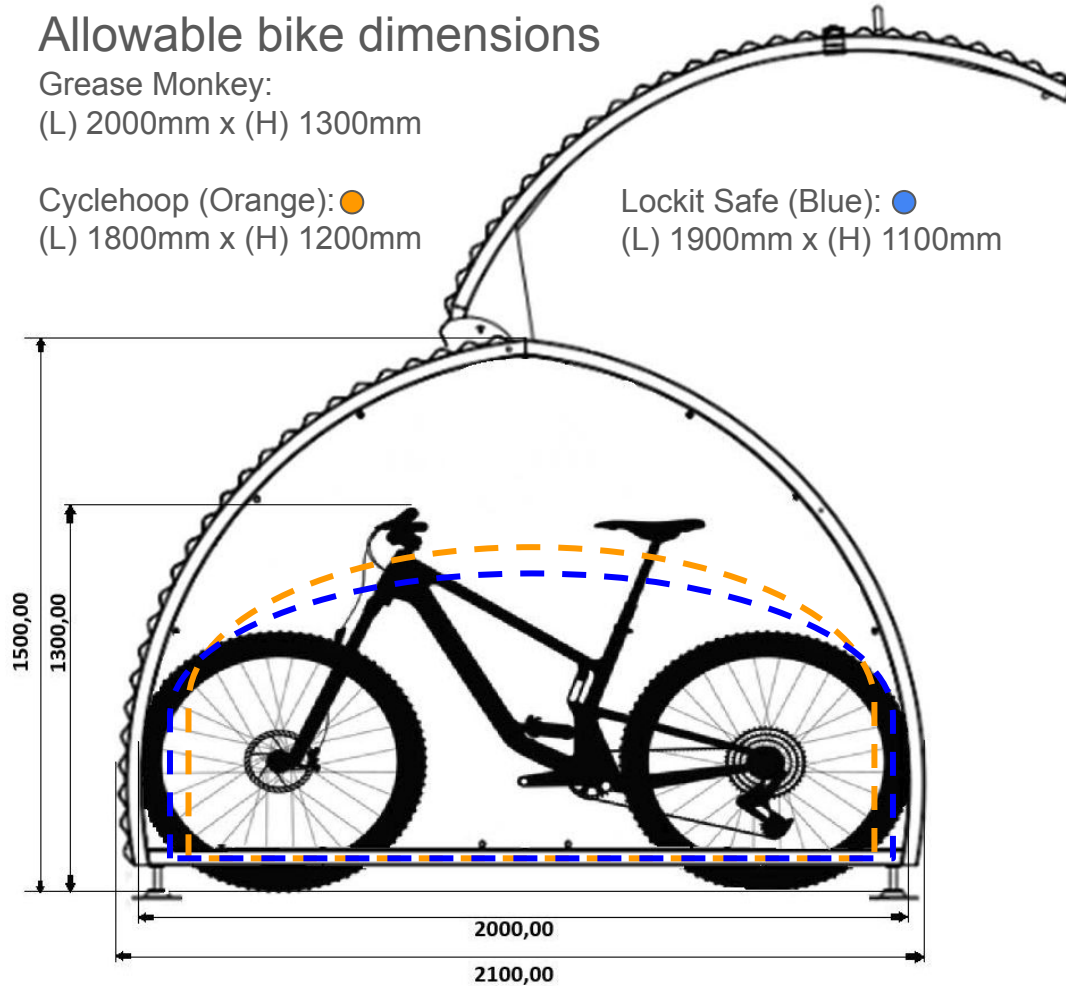

# Installation

## SETTING OUT DIMENSIONS

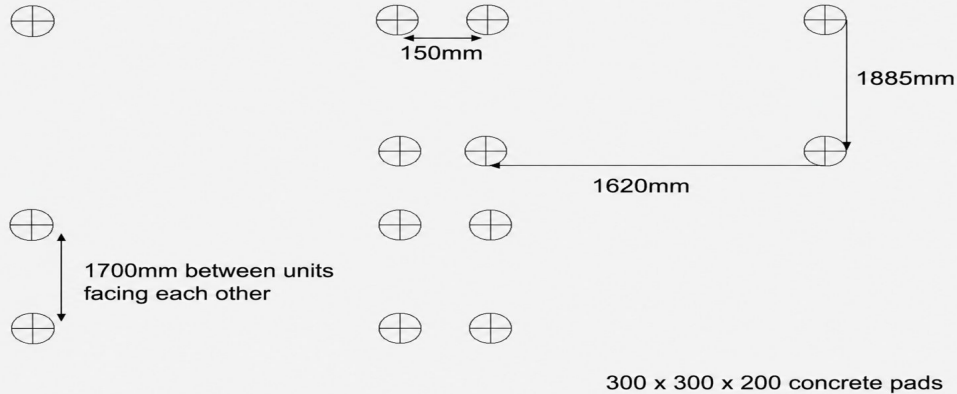

## BEFORE INSTALLATION

- Concrete base ST4 (standardised Prescribed Mix) min 100mm deep & at least 100 mm larger than footprint on each side, poured to adjacent levels or with suitable ramp for safe access.
- Concrete pockets (ST4 Standardised Prescribed Mix) are only suitable for use in mono block, cobbled or other sealed hard stand.

## INSTALLATION PROCESS

Units are located into position by rolling on skates or adjacent unloading via mini HIAB.

Access must be clear for unloading and use of skates. Skates can only be used on hard surfaces such as tarmac, concrete, or mono block. Any other surface is unsuitable.

## IMPORTANT INFORMATION:

The VeloBox can be installed on any firm, level hardstanding such as tarmac, concrete, or concrete slabs. A stable, continuous base is essential for correct commissioning, long-term performance, and safe daily use.

If the unit is positioned with its front feet on a kerb, the access door must still open onto a surface that is level with the base of the VeloBox. This ensures safe, inclusive, and comfortable access for all users. Any step, lip, or change in height at the doorway can hinder usability.

## Colour Chart

VeloBoxes are available in 15 standard colours.

Their cladding coating is a specially developed formulation designed to deliver superior performance, long-lasting colour stability, and outstanding resistance to weathering and degradation. A 200-micron plastic coating is applied to hot-dipped galvanised steel, with a light grey backing coat on the reverse. This durable plastic coating also provides an effective vandal-resistant finish.

The Velobox end panels are manufactured from pre-galvanised steel, etch-primed and powder-coated to match the chosen cladding colour, ensuring exceptional all weather protection.

Alternative colour schemes can be supplied on request, using customer-specified BS or RAL colour references. Please note that the colours shown are as accurate as possible, but variations may occur due to screen display limitations.

## Custom Decals.

Custom decals can be produced and fitted based upon customers supplied artwork,



# Velobox Integrated Product Solutions

## Leaf / Litter Protection Guards

Our add-on leaf and litter protection keeps cycle hangers clean and operational by preventing debris buildup, ensuring hassle-free use and reducing maintenance needs. Comprising of a sturdy wire mesh, which allows rainwater to escape. Combined with a rubber front door seal. This gives all round protection to your hangar. This can be either fitted upon installation of the hangar, or retrofitted at a later date. We also provide fitting to other manufacturers' hangars.



Digital Locking Systems We've partnered with Park My Bike to offer a selection of premium digital locking systems, using trusted solutions from EVVA, iLoq, and Salto. Whether you're looking for short-term access for public schemes or long-term rental for residential users, we can recommend the right locking system to match your needs. All smart locks are supported by robust digital infrastructure and come with associated subscription and service costs. We're happy to provide a detailed cost breakdown tailored to your specific requirements.



Combination Locking Systems Our hangars can be fitted, with high security robust electronic combination locks. To give businesses freedom to allow employees access without demanding key control or costly digital access.

Anchor point We can supply additional anchor points to our hangars. Giving options for motorcyclists to have a secure anchoring point. This can be fitted during assembly or added at any point.

Data Tracking Via magnetic sensors or LoRaWAN if infrastructure is present. Subject to the monitoring option selected, the following data can be made available:

- Number of openings and closings per unit
- Frequency of use over time (daily, weekly, monthly trends)
- Duration of use (where digital access is enabled)
- Identification of underused or high-demand units



## **Warranty**

Grease Monkey warrants our Veloboxes, bike shelters, bike racks and bike repair stations to the original Purchaser to be free from defects in material, structural integrity and workmanship within a 10 year period from the date of delivery and/or installation and will perform in accordance with provided original operation instructions if properly installed, used and cared for.

## **Terms of Warranty**

This warranty policy does not cover, and Grease Monkey shall not be liable for:

- Normal wear and tear
- Acts of nature, including but not limited to, earthquakes, floods, and hurricanes
- Misuse, abuse, vehicle collision or negligence
- Modification, alteration, or repair by unauthorised personnel
- Failure to follow the Product's assembly, installation, or maintenance instructions

Any Velobox, bike shelter, bike rack or bike repair station verified to be defective within the warranty period shall upon prompt notice by its Purchaser to our Customer Service Department, be either replaced or repaired at our sole discretion. Any warranty claim will not be processed without authorisation from customer service, a copy of the original invoice documenting date of purchase and/or installation and evidence that the unit has been maintained in accordance to provided guidelines. The Purchaser is responsible for all costs involved in sending any defective parts back to Grease Monkey and/or any call-out or labour costs related to a warranted repair. Grease Monkey may reimburse these costs as part of the warranty claim at our sole discretion. Warranty related enquiries should be addressed to the following email: [info@greasemonkey.cc](mailto:info@greasemonkey.cc)

## **Care/Maintenance Plan**

This Plan is a service provided by Grease Monkey which can be purchased as an addition to what is covered by the warranty policy. This plan provides additional cover which includes:

- Maintenance visits where units are cleaned, serviced and repaired where necessary.
- Free replacement of damaged parts covered by warranty
- Any damage outside the warranty coverage will be repaired at a discounted rate.
- Ensures proper care of unit in line with the terms of warranty

Coverage starts from the date of delivery and all enquiries must be carried out through our Customer Service Department. Any claims will not be processed without authorisation from customer service, a copy of the original invoice documenting purchase of the care plan and delivery date. The Purchaser is responsible for all costs involved in sending any defective parts back to Grease Monkey and/or any call-out or labour costs related to a warranted repair. Grease Monkey may reimburse these costs fully or partially in conjunction with warranty and care plan cover at our sole discretion.

For all warranty-related enquiries or to initiate a claim, please contact Grease Monkey Customer Service:

Email: [info@greasemonkey.cc](mailto:info@greasemonkey.cc)

Website: [www.greasemonkey.cc](http://www.greasemonkey.cc)



# GREASEMONKEY INFRASTRUCTURE

Unit 14 IO Centre  
Hatfield  
Hertfordshire  
AL10 9EW  
[jonathan@greasemonkey.cc](mailto:jonathan@greasemonkey.cc)  
07939956065

Unit 5 Napier Square  
Livingston  
Scotland  
EH54 5DG  
[info@greasemonkey.cc](mailto:info@greasemonkey.cc)  
0131 260 9739

[www.greasemonkey.cc](http://www.greasemonkey.cc)